

Product Brochure For C064

## 4MT Live Centre Set - Interchangeable Centring Tips

ORDER CODE:	C064
Taper (MT):	4MT
Maximum Speed (rpm):	~
Maximum Load Capacity (kg):	~
? Angle:	~
A:	~
B:	~
C:	~
D:	~
D1:	~
L:	~
Nett Weight (kg):	2.5

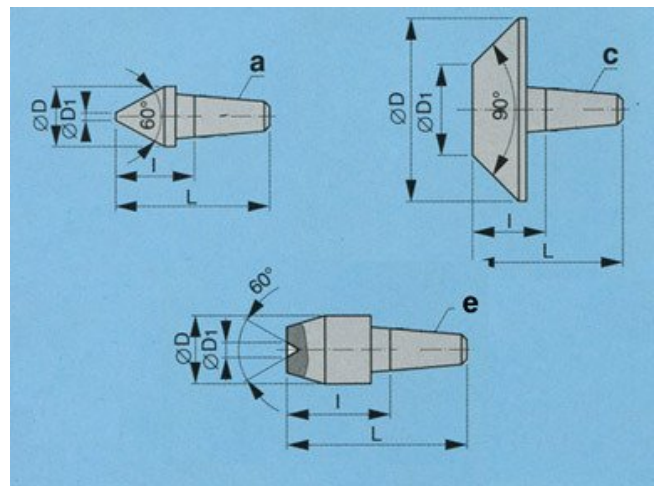

### Description

Toolmaster high speed live centre set with interchangeable centres. The body uses at the front a double row ball bearings and a thrust bearing with the main shaft supported at the other end with a needle roller bearing

### Features

- Complete with 7 interchangeable points for various operations
- Supplied in plastic blow-mould case
- Body manufactured from SC45C tool steel hardened to HRC-60 and precision ground
- Maximum speed 3000rpm
- Concentric 0.0005mm

### Includes

- 2 x A Type D=12.5mm L=32mm I=16mm
- 1 x A Type D=9.8mm L=38.6mm I=24mm
- 1 x A Type D=8mm L=38.6mm I=20mm
- 1 x A Type D=6mm L=38.6mm I=20mm
- 1 x C Type D=32mm D1=10mm L=40mm I=22mm
- 1 x E Type D=7.5mm L=32mm I=12mm