

Product Brochure For C411

## Industrial Caster Wheel Set - CW-125

Ø125mm Wheels  
 2 x Fixed, 2 x Swivel/Brake

**On Sale**

Ex GST

Inc GST

**\$130.00**

**\$143.00**

**\$108.18**

**\$119.00**

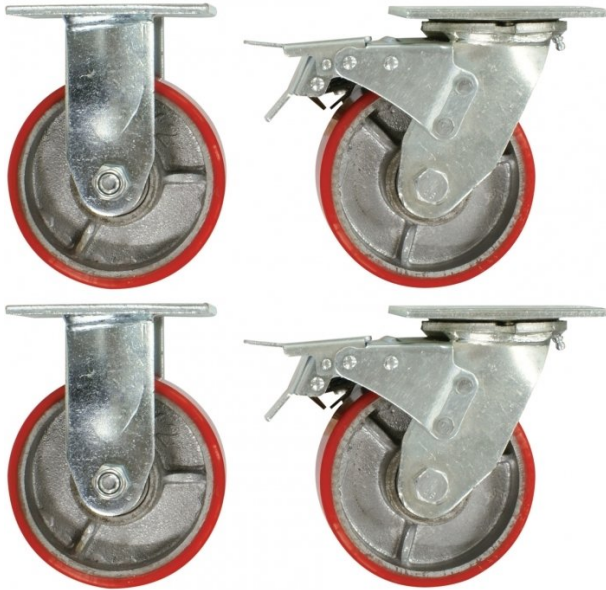

ORDER CODE:	C411
MODEL:	CW-125
Quantity of Wheels in Pack (No.):	4
Wheel Type:	2 Fixed, 2 Swivel/Brake
Wheel Diameter (mm):	Ø125
Wheel Width (mm):	50
Total Height to Top of Plate (mm):	165
Load Capacity per Wheel (kg):	410
Load Capacity per Set (kg):	1640
Nett Weight (kg):	16



### Description

Industrial quality Ø125mm caster wheels, Tyre is made from tough elastic rubber with an load capacity of up to 410kg per caster.

### Features

- Ø125mm x 50mm wide steel wheel with bonded polyurethane
- 2 x fixed wheels
- 2 x swivel wheels with brake
- 410kg each wheel capacity
- Brake also locks wheel from swivelling
- Swivel base incorporates ball bearings
- Ball bearing sealed race on main shaft
- 165mm overall height from base of wheel to top of plate
- Mounting plate 114 x 102mm with 4 slotted holes

Product Brochure For C411

**Specific Features**



Ball Bearings Base with Greasing Nipple



Foot Brake With Swivel Base Lock



Foot Brake Activated



Foot Brake Released



Top View

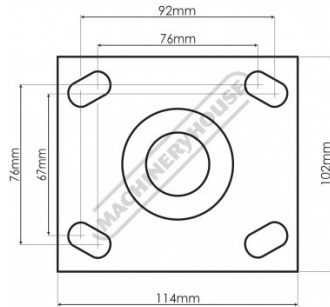

Base Diagram

**Recommended Accessories**

**W935**

Caster Wheels - Side Mount

**C410**

Heavy Duty Caster Wheel Set

