

Product Brochure For C414

Industrial Caster Wheels - CW150S

Ø150mm Wheels
 2 x Swivel/Brake



On Sale

Ex GST

~~\$90.00~~

\$76.36

Inc GST

~~\$99.00~~

\$84.00

ORDER CODE:	C414
MODEL:	CW-150S
Quantity of Wheels in Pack (No.):	2
Wheel Type:	2 Swivel/Brake
Wheel Diameter (mm):	Ø150
Wheel Width (mm):	50
Total Height to Top of Plate (mm):	~
Load Capacity per Wheel (kg):	450
Load Capacity per Set (kg):	900
Nett Weight (kg):	9



Description

Industrial quality & 150mm castor wheels, Tyre is made from tough elastic rubber with an load capacity of up to 450kg per castor.

Features

- Ø150mm x 50mm wide steel wheel with bonded polyurethane
- 2 x swivel wheels with brake
- 450kg each wheel capacity
- Brake also locks wheel from swivelling
- Swivel base incorporates ball bearings
- Ball bearing sealed race on main shaft
- Mounting plate 114 x 102mm with 4 slotted holes

Product Brochure For C414

Specific Features



Foot Brake Activated



Foot Brake Released



Top View



Ball Bearings Base with Greasing Nipple



Foot Brake With Swivel Base Lock

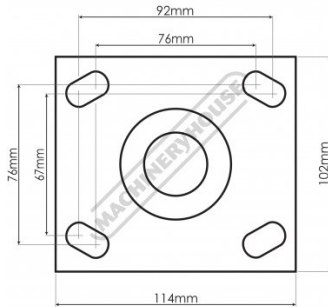

Base Diagram

Recommended Accessories

A380
 Steel Work Bench - 3 x Lockable
 Drawers

