

Product Brochure For D829

## Boring Sleeve - Straight - CHR 32-40

Suits CNC Lathes  
 Ø40mm x Ø32mm



Ex GST  
**\$80.00**

Inc GST  
**\$88.00**

ORDER CODE:	D829
MODEL:	CHR 32-40
Type:	Slot
OD (mm):	40
ID (mm):	32mm
L (mm):	96
L1 (mm):	66

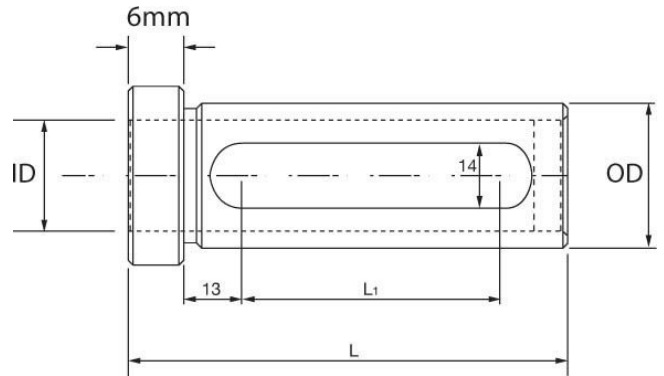

### Description

Used in the turrets of CNC lathes to hold boring bars and other cutting tools.  
 Universal design allows these sleeves to be fitted to all CNC machines with turrets

### Features

- Precision ground
- Slotted so that the turret clamp screws can clamp directly onto the boring bar or cutter