

Product Brochure For H251

Electric Chain Hoist - TECH0106

1 Tonne x 6 Metre Lift
 Dual Speed: 6m/min. Lift Speed



Ex GST **Inc GST**
\$2,205.00 **\$2,425.50**

ORDER CODE:	H251
MODEL:	TECH0106
Capacity (Tonne):	1
Lift Height (Metre):	6
Lift Speed (m/min):	6
Motor Power (W):	1200
Voltage (V):	240



Description

Thermal Prevention Device Fitted

Features

- Light weight, compact design with high efficiency motor
- Pressed steel structure, high strength body
- High tensile alloy steel top & bottom hooks
- Grade 80 - 7.1mm Alloy Steel load chain
- Limit switches fitted at top and bottom ends to prevent chain run-out
- 240V , 50Hz Dual speed Motor 1200 Watts

Optional Accessories

- Available with customisable chain lengths and an optional wireless remote for added convenience (additional costs may apply)

Main Dimension of TECH Series Electric Chain Hoist

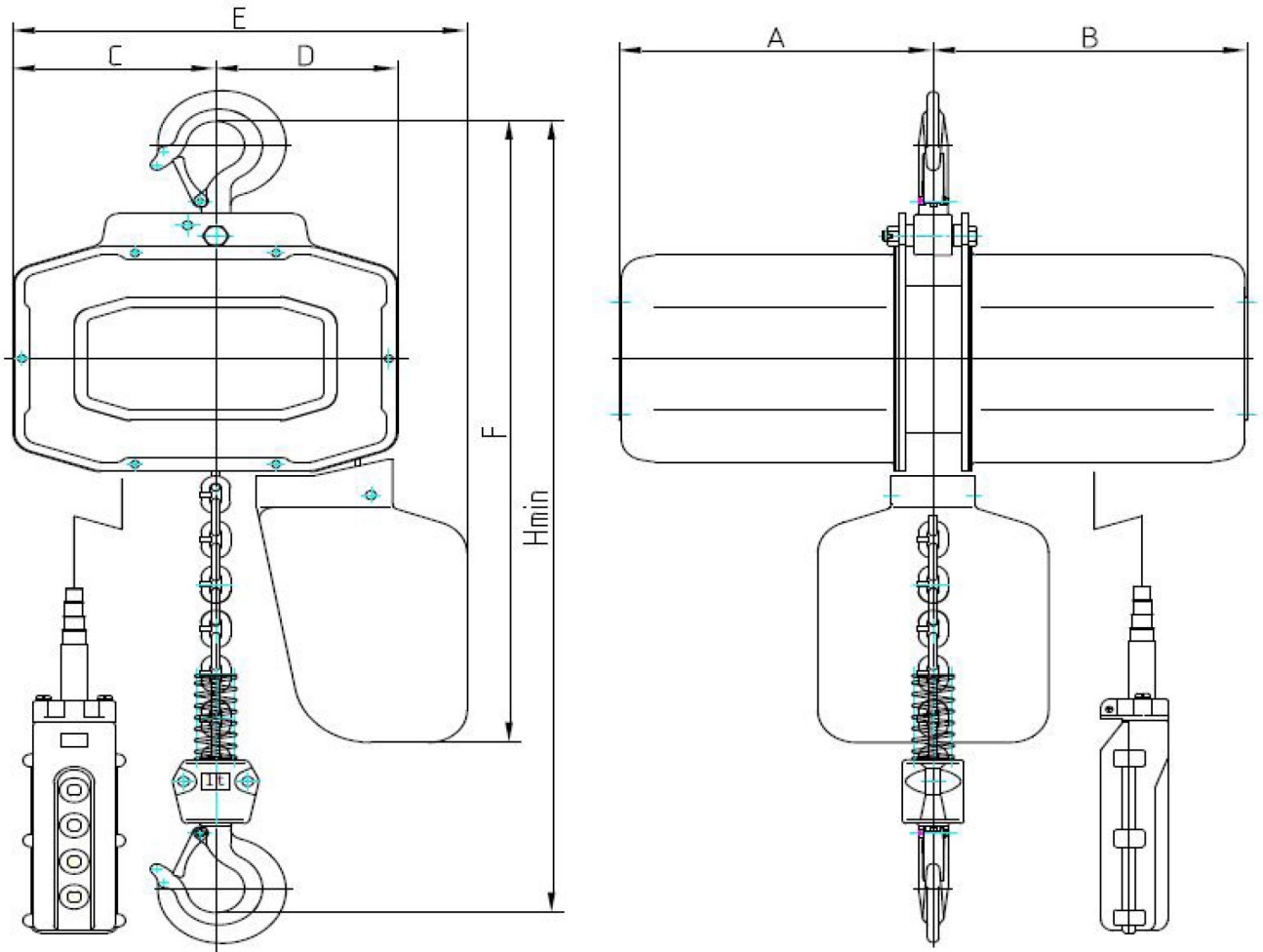

Model	TECH0103 / TECH0106	TECH0203 / TECH0206
A	245	245
B	245	245
C	158	124
D	142	176
E	350	350
F	600	610
H	520	630

Product Brochure For H251

Recommended Accessories

C147
 Girder Trolley



C146
 Girder Clamp



H352
 13mm 2T Grade S - Lifting Bow Shackle



H350
 11mm 1.5T Grade S - Lifting Bow Shackle



H308
 Round Slings



H307
 Round Slings



H306
 Round Slings



H320
 Flat Slings



Product Brochure For H251

H322
Flat Sling



H312
Round Sling



H313
Round Sling



C188
Mobile Girder Rail Gantry



C191
Digital Crane Scale

