

Product Brochure For H2552

## Electric Chain Hoist - TECH3PH2SP0203

2 Tonne x 3 Metre Lift  
 Dual Speed: 6.6m/min. Lift Speed

**Special Order**

<b>Ex GST</b>	<b>Inc GST</b>
<b>\$3,360.00</b>	<b>\$3,696.00</b>



ORDER CODE:	H2552
MODEL:	TECH3PH2SP0203
Capacity (Tonne):	2
Lift Height (Metre):	3
Lift Speed (m/min):	6.6
Motor Power (W):	3.0kw
Voltage (V):	415



### Description

The TOHO Three Phase 415V Electric Chain Hoist is purpose-built for heavy-duty lifting applications, providing the strength and reliability required to move larger and heavier loads with ease.

Backed by TOHO's reputation for quality, durability, and performance, this hoist delivers dependable operation across a wide range of industrial environments. With decades of proven reliability in Australasia, TOHO electric chain hoists are trusted for demanding applications where safety and efficiency are critical.

Each model is tested in accordance with AS1418.2 standards, ensuring compliance and peace of mind. Designed for versatility, the TOHO 3-Phase hoists offer an extensive operating range that makes them well-suited to most lifting applications

### Features

- Light weight, compact design with high efficiency motor
- Pressed steel structure, high strength body
- High tensile alloy steel top & bottom hooks
- Grade 80 - 7.1mm Alloy Steel load chain
- Limit switches fitted at top and bottom ends to prevent chain run-out
- High quality chain 7.1mm diameter
- 415V, 50Hz Dual speed Motor 3.0kw. (3 Phase)
- Complies with ASNZS 1418.2 standard
- IP Rating Hoist: IP54 Control: IP65

### Includes

- Thermal Prevention Device Fitted
- Limit switches fitted at top and bottom ends to prevent chain runout
- Load Limited
- Emergency Stop Button

### Optional Accessories

- Available with customisable chain lengths and an optional wireless remote for added convenience (additional costs apply)

## Main Dimension of TECH Series Electric Chain Hoist

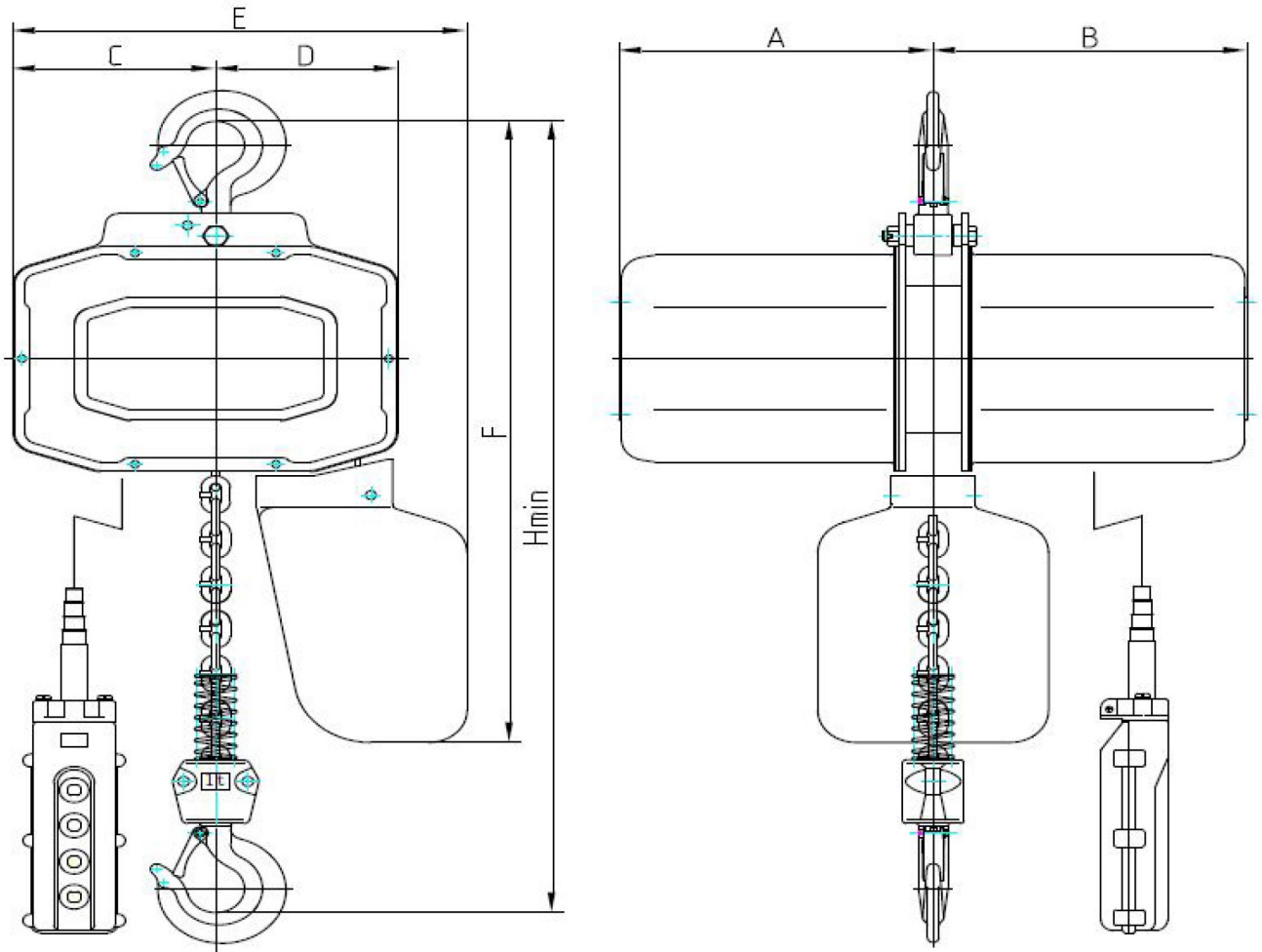

Model	TECH0103 / TECH0106	TECH0203 / TECH0206
A	245	245
B	245	245
C	158	124
D	142	176
E	350	350
F	600	610
H	520	630

Product Brochure For H2552

**Recommended Accessories**

**C148**  
 Girder Trolley



**H352**  
 13mm 2T Grade S - Lifting Bow Shackle



**H311**  
 Round Slings



**H314**  
 Round Slings



**H312**  
 Round Slings



**H313**  
 Round Slings



**H322**  
 Flat Slings



**H324**  
 Flat Slings

