

Product Brochure For K108

Professional Hydraulic Steel Trolley Jack & Axle Stands Package Deal - TJA-2SL

Jack - 2000kg (2 Tonne) & Stands - 3000kg (3 Tonne)
 Jack - 95 ~ 470mm Lift Height & Stands - 295 ~ 440mm Height



| | |
|--|----------------------|
| ORDER CODE: | K108 |
| MODEL: | TJA-2SL Package Deal |
| Trolley Jack Load Capacity (kg / Tonne): | 2000 / 2 |
| Trolley Jack Lift Height (mm): | 95 ~ 470 |
| Trolley Jack Fabricated Material (Type): | Steel |
| Axle Stands Load Capacity (kg / Tonne): | 3000 / 3 |
| Axle Stands Height (mm): | 295 ~ 440 |
| Nett Weight (kg): | 42 |



Description

Professional premium quality low profile trolley jack
 Tested to Australian standards

Features

- ARMGT2 - Professional Hydraulic Trolley Jack - Steel
 - 2,000kg capacity
 - Low profile 95mm minimum height, perfect for jacking vehicles with low ground clearances
 - Professional, premium quality low profile trolley jack
 - Manufactured and individually tested in Europe
 - Manufactured to meet the strictest international safety standards
 - Fitted with polyamide wheels and castors to facilitate manoeuvrability
 - Foot pedal for quick approach of lifting saddle to load
 - 900mm jack length, 1610mm long with handle
 - 360mm wide at rear and 257mm wide at front of jack
 - Safety overload valve which prevents the jack from being used beyond the rated capacity
 - Lowering operation by the "dead man's" principle (the operation is halted if the user accidentally loses control)
 - High quality durable seals and internal components for extended service life
 - Tested to AS/NZS 2693, ANSI PALD & EN1494 Standards
-
- ARMAS3000R - Professional Vehicle Axle Stands - Steel
 - Capacity 3000kg per stand
 - Heavy duty, high quality ratchet type axle stands
 - Tested to Australian standards
 - A high quality axle stand that provides a safe & efficient means of supporting vehicles
 - Sturdy welded construction for added safety & strength
 - One piece ratchet bar provides superior strength & durability
 - Easy to use quick adjustment mechanism that securely locks stands into position
 - Stands are individually rated i.e. capacity rating refers to per stand not per pair
 - Supplied and priced as a set of 2 stands.

Product Brochure For K108

TECHNICAL SHEET

| Capacity (t) | A | B | C | D | E | F | G | H | Weight (kg) |
|--------------|----|-----|-----|-----|-----|------|-----|-----|-------------|
| 2 | 95 | 135 | 470 | 850 | 900 | 1610 | 360 | 257 | 35 |

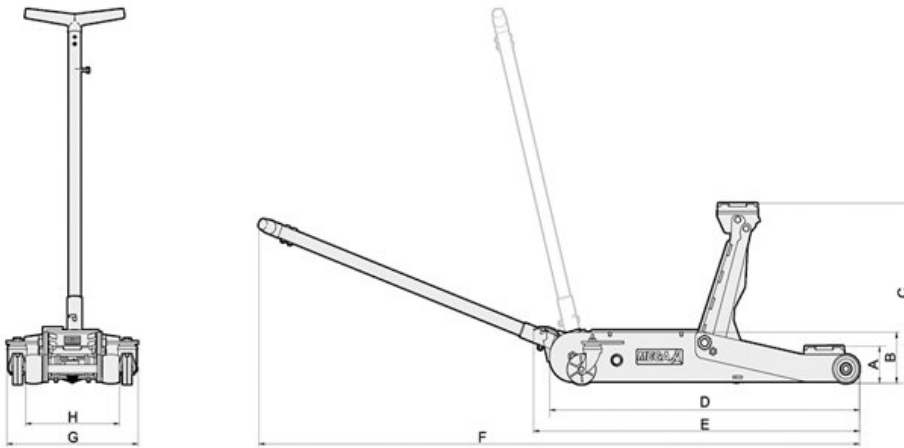

Specific Features



Trolley Jack



Axle Stands



Shown At Lowest and Highest Ratchet Position



Front and Rear Views



Pick Up Tool



LED Light

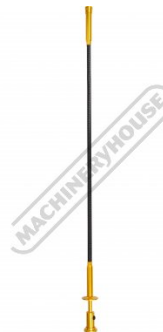

Extended



Light Button

Product Brochure For K108

Recommended Accessories

A332

Hydraulic Vehicle Positioning
Jacks

