

Product Brochure For L298

## Quick Change Toolpost - Model D

350mm Lathe Centre Height



**Ex GST**                      **Inc GST**  
**\$1,540.00**                  **\$1,694.00**

ORDER CODE:	L298
MODEL:	D
Lathe Centre Height (mm):	350
Lathe Swing (mm):	700
A (mm):	34
B (mm):	21
C (mm):	137
D (mm):	175
E (mm):	~
H (mm):	61 - 95
h (mm):	120
S (mm):	42
T (mm):	40
Y (mm):	~
Number of Sides (No.):	3
Number of Holders (No.):	5
Nett Weight (kg):	57



### Description

Manufactured from carbonized and hardened steel.  
 Italian design style.

### Features

- All bearing surfaces are precision ground to ensure rigidity
- Handy lathe accessory for tool rooms and general engineering shops
- Ease of operation cuts set-up time by 90%
- No shims are required to adjust tools to correct centre height
- Easily fitted to most centre lathes
- Please Note: Some machining required to suit your lathe

### Includes

- 4 x Square Tool Holders - for 40mm tools
- 1 x Vee Tool Holders - for boring bars

### Optional Accessories

- Holders - L298A

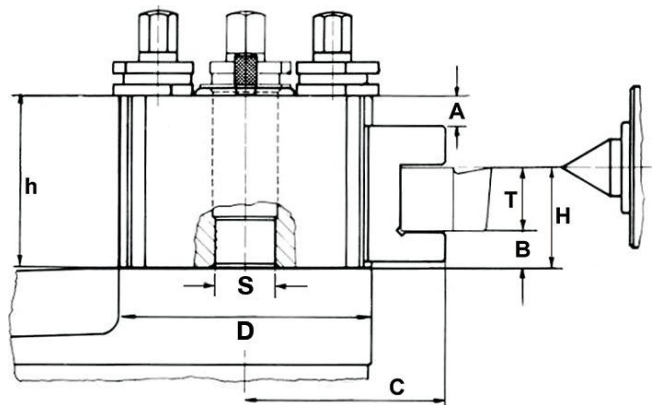

## Product Brochure For L298

---

### Recommended Accessories

L298A

Quick Change Toolpost Holder -  
Std

