

Product Brochure For M167

NT40-MT2-40 Milling Adaptor



On Sale

Ex GST	Inc GST
\$90.00	\$99.00
\$77.27	\$85.00

ORDER CODE:	M167
MODEL:	NT40-MT2-40
Outer Taper:	NT40
Inside Taper:	MT2
Drawbar Thread (mm / inch):	16mm
L (mm):	40
C (mm):	32
Nett Weight (kg):	1.00

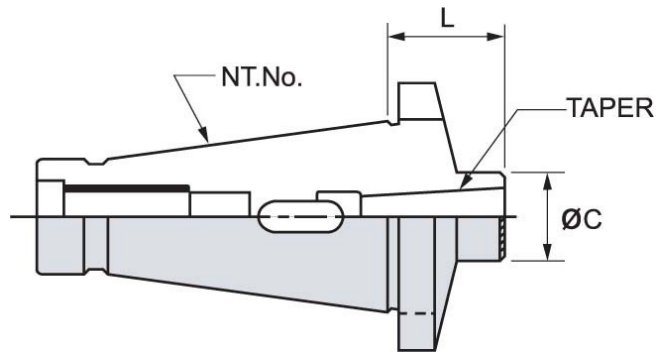

Description

Precision ground and hardened.
 Morse taper adaptors are used to adapt a Morse taper tool or cutter to any spindle taper