

Product Brochure For M1724

NT40-NT30 Milling Adaptor

**On Sale**

<b>Ex GST</b>	<b>Inc GST</b>
<del>\$100.00</del>	<del>\$110.00</del>
<b>\$86.36</b>	<b>\$95.00</b>



ORDER CODE:	M1724
MODEL:	NT40-NT30
Outer Taper:	NT40
Inside Taper:	NT30
Drawbar Thread (mm / inch):	~
L (mm):	15
C (mm):	~
Nett Weight (kg):	1.00

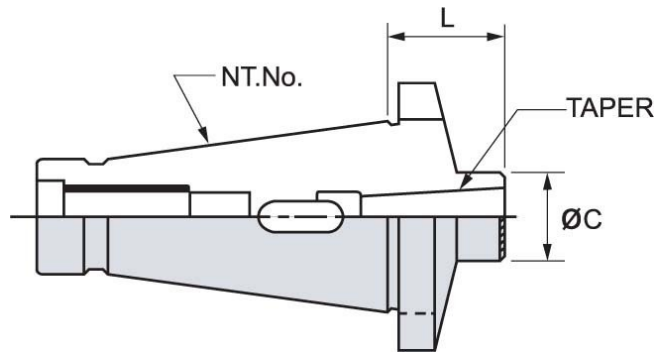

**Description**

Precision reducing adaptor for NT40 to NT30

**Features**

- External and Internal taper precision ground
- Please Note:
- Requires a M12 drawbar to be made long enough to reach NT30 holder
- Not recommended for use on machines with air powered drawbar

## NT40 x NT30 Adaptor



### M12 Drawbar

Drawbar needs to go through Adaptor  
and secure into the NT30 Tooling