

Product Brochure For M517

Face Mill 45° - Super High-Rake - F45SE12-D80

Ø80mm

Insert tip not included

On Sale

Ex GST	Inc GST
\$150.00	\$165.00
\$135.45	\$149.00



ORDER CODE:	M517
MODEL:	F45SE12-D80
Cutter Approach Angle (deg):	45°
D (mm):	80
D1 (mm):	93
H (mm):	50
d (lowercase):	27mm
Drawbar Thread:	-
Number of Inserts (No.):	6
Replacement Insert Tips:	(L065)
Nett Weight (kg):	1.35



Description

SUPER HIGH-RAKE FACE MILL - 80mm x 45°
 Use carbide inserts (ISO) SEKT1204 (L065)
 NOTE: Carbide Inserts not included

Features

- Suitable for low horsepower machines where rapid metal removal is required.
- Suitable for steel, cast iron and non-ferrous metals
- Positive rake

Includes

- Lock key for insert

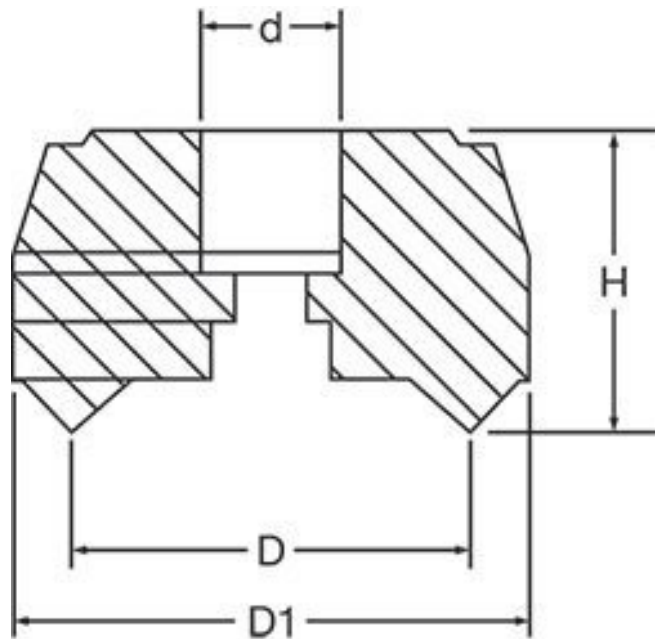

Product Brochure For M517

Recommended Accessories

L065

KYOCERA Carbide Inserts -
 Milling



ML090

Cutter Part - Screw



L538

Key to Suit Tool Holder



M563

Face Mill Arbor



M536

Face Mill Arbor



M542

Face Mill Arbor



M552

Face Mill Arbor



T155

BT40-FMB27-45 Face Mill Arbor

