

Product Brochure For M537

Face Mill Arbor - R8 - FMB32-20



On Sale

Ex GST
\$70.00
\$59.09

Inc GST
\$77.00
\$65.00

ORDER CODE:	M537
MODEL:	R8 - FMB32-20
Draw Bar (mm / inch):	7/16"
D (mm):	32
H (mm):	20
K (mm):	7
C (mm):	54
L (mm):	20
Nett Weight (kg):	1.20

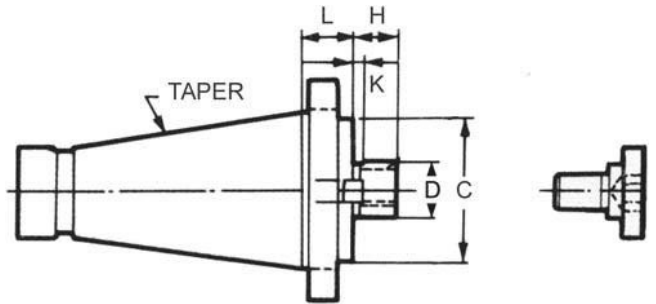

Features

- Material: SCM-21
- Hardness: HRC 50° - 55°
- Squareness of mounting surface: Less than 0.0002" (0.005mm)
- Deflection in shaft and taper: Less than 0.0002" (0.005mm)

Product Brochure For M537

Recommended Accessories

M513

Face Mill 90° - Positive Rake

M518

Face Mill 45° - Super High-Rake

