

Product Brochure For N010

Rivet Nut Inserts - M10 x 1.5mm

Steel - Zinc Plated
 Qty 50 In Pack

On Sale

Ex GST
~~\$22.00~~
\$18.18

Inc GST
~~\$24.20~~
\$20.00



ORDER CODE:	N010
MODEL:	~
Type:	Rivet Nut Inserts
Nut Insert Material (Type):	Steel - Zinc Coated
Quantity in Pack:	50
Rivet Nut Inserts Range (Metric):	~
Blind Rivets (mm):	~
Thread Size (T) (Metric):	M10 x 1.5
Thread Length (TL) (Metric):	~
Length (L) (mm):	18.5
Head Height (HH) (mm):	1.5
Head Diameter (HD) (mm):	17.15
Diameter (D) (mm):	12.9
Hole Size (HS) (mm):	13
Grip Range (GR) (mm):	1.00 - 4.00
Torque to Turn (Kgf.cm):	400



Description

Suits ATR-10RN Air Operated or RNB40 Twin Handle Nut Riveters

Features

- Steel - Zinc Coated
- Fast & easy installation from one side
- Adds a threaded nut to thin sheet metal
- Knurled section under nut head for anti-rotation
- Easy to install

Includes

- 50 x Rivet Nut Inserts - M10 x 1.5mm

NUT INSERT

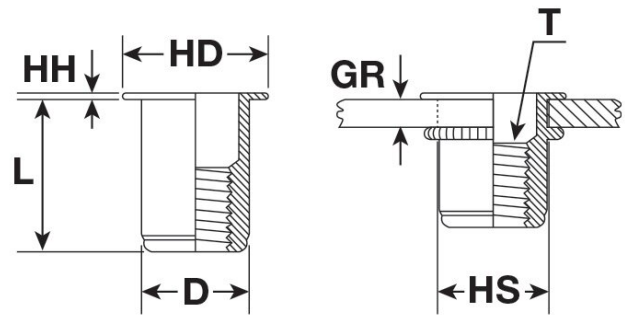

UNINSTALLED

INSTALLED

Product Brochure For N010

Specific Features



Packaging Front



Packaging Rear Side

Recommended Accessories

N001

Nut & Blind Riveter Set - 130 Piece



N005

Rivet Nut Inserts - M5 x 0.8mm



N006

Rivet Nut Inserts - M6 x 1.0mm



N008

Rivet Nut Inserts - M8 x 1.25mm



N015

Rivet Nut Inserts - M5 x 0.8mm



N016

Rivet Nut Inserts - M6 x 1.0mm



N018

Rivet Nut Inserts - M8 x 1.25mm



N020

Rivet Nut Inserts - M10 x 1.5mm

