

Product Brochure For N028

Rivet Stud Inserts - M8 x 1.25mm

Steel - Zinc Plated
 Qty 50 In Pack



On Sale

Ex GST
\$45.00
\$40.91

Inc GST
\$49.50
\$45.00

ORDER CODE:	N028
MODEL:	~
Type:	Rivet Stud Inserts
Nut Insert Material (Type):	Steel - Zinc Coated
Quantity in Pack:	50
Rivet Nut Inserts Range (Metric):	~
Blind Rivets (mm):	~
Thread Size (T) (Metric):	M8 x 1.25
Thread Length (TL) (Metric):	20
Length (L) (mm):	16.4
Head Height (HH) (mm):	1.5
Head Diameter (HD) (mm):	15
Diameter (D) (mm):	10.9
Hole Size (HS) (mm):	11
Grip Range (GR) (mm):	1.00 - 3.00
Torque to Turn (Kgf.cm):	200



Description

Suits RNB40 Twin Handle Nut Riveter

Features

- Steel - Zinc Coated
- Fast & easy installation from one side
- Adds a threaded stud to thin sheet metal
- Knurled section of the body for anti-rotation
- ** Easy to install with the RNB40 Nut Riveter
- ** NOTE: Requires M8 Stud Rivet Mandrel, sold separately (Order Code: N023)

Includes

- 50 x Rivet Stud Insert - M8 x 1.25mm
- 20mm thread length

STUD INSERT

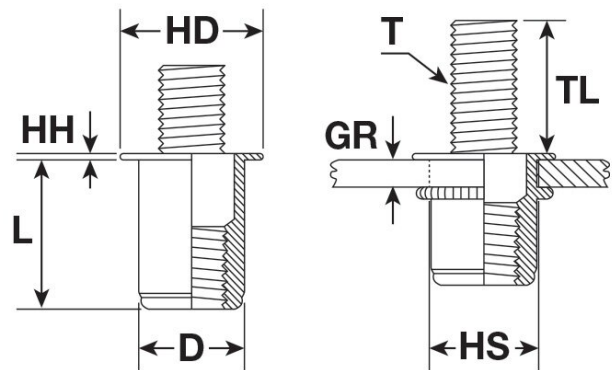

UNINSTALLED

INSTALLED

Product Brochure For N028

Specific Features

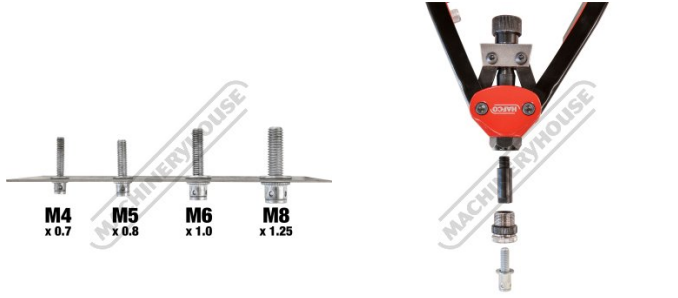

Stud Range N024 28

Shown with Optional Mandrel Adaptors N023 and Riveter Set N001

Recommended Accessories

N001

Nut & Blind Riveter Set - 130 Piece



N023

Rivet Stud Mandrels - M5, M6, M8



N025

Rivet Stud Inserts - M5 x 0.8mm



N026

Rivet Stud Inserts - M6 x 1.0mm



N024

Rivet Stud Inserts - M4 x 0.7mm



N022

Rivet Stud Mandrel & Adaptor - M4

