

Product Brochure For Q1985

Vernier Calipers - 33-1985

600mm/24" & #34
 Large Mono Block

On Sale

Ex GST	Inc GST
\$380.00	\$418.00
\$320.00	\$352.00



ORDER CODE:	Q1985
Range (mm / inch):	600mm / 24"
Graduations (mm / inch):	0.02mm / 0.001"
Accuracy (mm):	±0.05
J (mm):	150
B (mm):	10
C (mm):	12
D (mm):	25

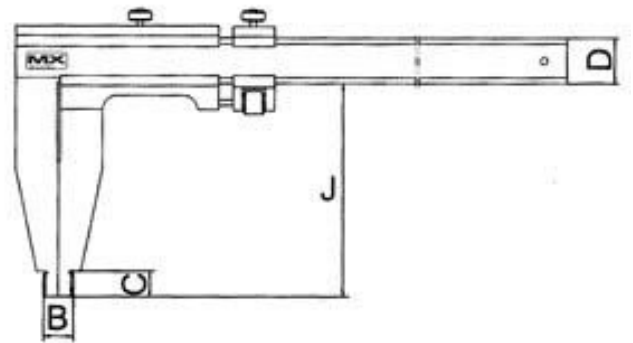

Features

- Precision vernier calipers with stainless steel body and slides
- Mono-block design
- Supplied in wooden case
- Instrument are manufactured to ISO 10012:2003
- An ISO9001:2000 Company
- Clear graduations - Metric/Imperial graduations
- Long Jaw style

Product Brochure For Q1985

Specific Features



Full View



Metric and Imperial Graduations