

Product Brochure For Q316

## Metric Outside Micrometer - Large Cast Frame - 12-316

125 - 150mm Range

**On Sale**

Ex GST

Inc GST

~~\$120.00~~

~~\$132.00~~

**\$101.82**

**\$112.00**



ORDER CODE:	Q316
Range (mm):	125 - 150
Graduation (mm):	0.01
Accuracy (mm):	0.006
Setting Bar (No.):	1
a (mm):	16.5
b (mm):	3
c (mm):	85
L (mm):	158
m061:	~

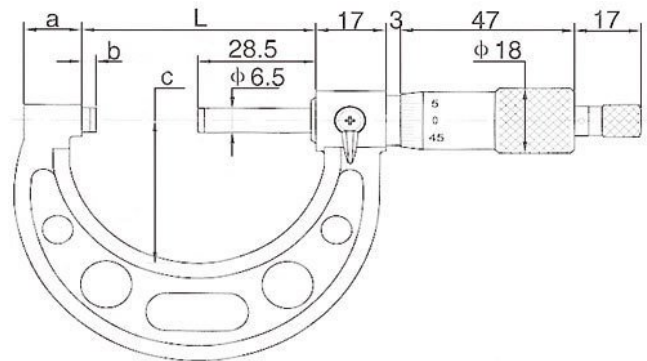

### Description

Measumax metric micrometers represent exceptional value. Special care has been taken in design and workmanship to ensure high precision and long life. Measumax metric micrometers meet industry standards for specification and accuracy

### Features

- Carbide measuring faces - Painted cast frame
- Micro-fine clear graduations on satin chrome finish
- Measuring face 6.5mm, Flatness 0.0008mm
- Ratchet stop for exact repetitive readings
- Includes deluxe foam lined plastic case and wrench
- Graduation 0.01mm
- Supplied with setting standards