

## Product Brochure For S902

# Hydraulic NC Pressbrake - PB-70B

70T x 3200mm

Estun NC-E21 Control 2-Axis with Ballscrew Backgauge



ORDER CODE:	S902
MODEL:	PB-70B
Control Unit (Type):	Estun NC-E21
Nominal Pressure - Tonnage (Ton):	70
Nominal Pressure - Kilonewtons (kN):	630
Length of Work Table (mm):	3200
Distance Between Columns (mm):	2650
Throat Depth (mm):	250
Maximum Open Height (mm):	360
Ram Stroke (mm):	100
Machine Axis (No.):	2
Safety Guarding System (Type):	~
Backgauge Travel (mm):	520
Table Bed Crowning System (Type):	~
Motor Power (kW / hp):	5.5 / 7.5
Motor Voltage (V):	415
Floor Space Requirements (L x W x H) (mm):	3900 x 1900 x 2400
Nett Weight (kg):	5740



## Description

MetalMaster Quality Pressbrakes feature high durability, and provide precision bending capabilities. The Pressbrake main frames are constructed from rolled, stress relieved solid steel to prevent distortion during the bending process and under extreme continuous loads.

MetalMaster Pressbrakes are produced in a high volume production process and therefore are able to be manufactured cost effectively, resulting in affordable price, representing value for money and quicker return on investment.

Featuring an adjustable synchronised torsion bar with positive stop system ensures consistent and accurate bending beam parallelism tolerance to 0.01mm via the digital Control unit.

All electrical components are of European quality supplied by, Telemecanique, Merlin Gerin and ABB.

Note: Guarding systems are required on pressbrakes for OHS compliance. See options below

## Features

- Hydraulic / Mechanical ram, synchronised positive stop design, ram stroke controlled by precision mechanical nut depth stops built into each cylinder. Electronically controlled by Estun NC-E21 digital control assuring accurate repeatability.
- Parallelism is ensured by torsion bar that can be easily adjusted by clutch system.
- Estun NC-E21 programmable digital control stores up to 40 unique programs with 25 automatic progressive bending steps in each individual program, assuring production accuracy & repeatability every time.
- Estun NC-E21 programmable hardened ballscrew backgauge system, simply enter the desired measurement into the controller and press go, the backgauge then will move quickly into the position you have requested. The superior hardened ballscrew system eliminates any backlash that leadscrew type machines produce.
- Segmented heavy duty 35° offset top punch is segmented for return bend clearance, complete with European style punch holder with an adjustable wedge clamping system for crowning. Intermediate clamp has safety key to stop punch dropping.
- Multi vee ('V') bottom die is made from one 3200mm solid die block design to handle heavy plate, safety edge vee ('V') is incorporated in bottom die block.
- Conveniently mounted control box on pendant for quick swivel and adjustments.
- Mono-block steel frame design, welded then machined to ensure minimal bed deflection under load
- Enclosed rear gate with micro safety switches complete with sliding rear door for easy access.
- European Style Intermediate clamping system, allowing operator to change position of tooling to suit multiple requirements on complex applications. This feature ensures minimum down time, more productivity and results in reduced cost per finished product.
- Sliding steel fabricated sheet supports enabling a wide range of material sizes to be aligned and supported at the correct required height. This feature is achieved with a "T" slot machined down the total length of the die bed; sheet supports are also adjustable vertically to assist in supporting material with return bends already folded.

## Product Brochure For S902

- Adjustable sliding blocks control the machines beam to provide desirable open height distance to the (slow speed) mute bending point.
  - Operator adjustable locking knobs for quick adjustment, enables accurate repeatability and increased productivity.
  - Metal safety guarding surrounding the machine with rear sliding door fitted and micro switch ensuring operator safety. Clear access panels placed at each end of machine allows the operator to clearly view tooling and work piece during bending operation. MetalMaster specially design gates to suit Australian safety requirements.
  - Hydraulic MPA pressure gauge mounted on right side of support frame with quick adjusting pressure control knob allowing operator to accurately set the pressure required for different material thickness, incorporating with hydraulic overload protection.
  - Welded steel fabricated synchronised torsion bar horizontally supporting main bending beam to provide consistent parallelism that also can be adjusted for taper correction.
  - The vertical supporting slides are treated to provide greater ware resistance and increased accuracy.
  - Mild steel capacity is rated on hot rolled material with 250MPA
- Pre-Commissioning:
    1. Pressbrake is run & tested prior delivery
    2. Hydraulic oil is included with machine

### Includes

- Operated by ESTUN NC- E21 control mounted on a swivel pendant for optimal ergonomics
- LED superior bright work lights provides clearer view to workpiece
- Sliding front sheet support arms
- Emergency stop buttons conveniently located on control panel and foot control
- Mobile dual operation foot control
- Segmented 35° offset top tooling
- Solid one piece four way multi vee (V) die block
- Top tooling tool intermediate holder system with wedge type adjustment
- Premium linear way side mount ballscrew backgauge with 520mm travel
- Metal constructed safety guarding surrounding machine with clear side viewing panels
- Integrated hydraulic system allowing rapid approach switching automatically to slow bend

### Specific Features



NC Estun E21 Controller



NC Estun E21



Adjustable Travel Limit Control



Enclosed Rear Safety Guarding

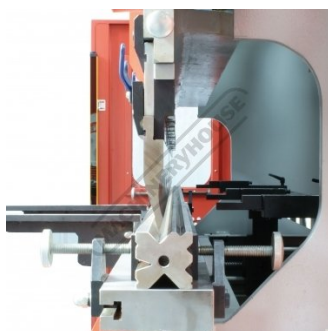

Top & Bottom Tooling



Intermediate Clamps



Adjustable and Sliding Front Sheet Supports



Adjustable Pressure Control

Product Brochure For S902



Estun NC E21 Control Ballscrew Back Gauge



Mobile Foot Control



Mobile Foot Control-Top Buttons



Adjustable Top Tool Taper Wedge System

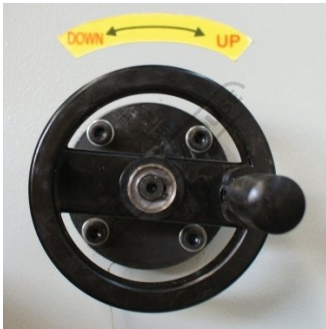

Fine Adjustment Beam Positioning



Fine Adjust Backgauge



Synchronised Torsion Bar



Synchronised Torsion Bar

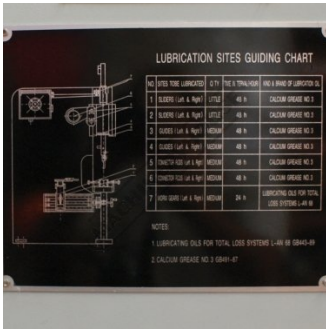

Lubrication Chart

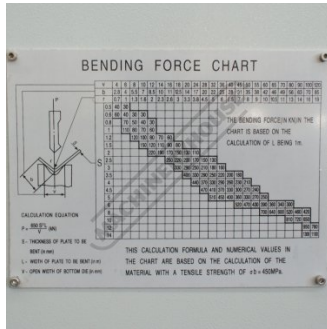

Tonnage Calculation Chart

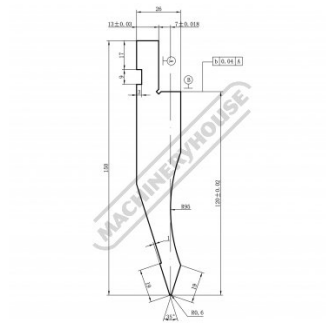

Segmented Top Punch

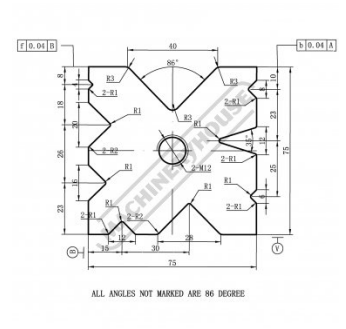

One Piece 4 Sided Die



Shown with Optional Ball Transfer Tables - Order Code (L840)



Fitted With OHS Compliant G Light Curtain Guarding System



Fitted With OHS Compliant GL Light Curtain Guarding System

Product Brochure For S902

**Recommended Accessories**

**S988**  
 Quick Action Intermediate  
 Clamps



**S990S**  
 35° Top Punch Pressbrake  
 Tooling - Segmented



**S990**  
 35° Top Punch Pressbrake  
 Tooling



**S990F**  
 35° Top Punch Pressbrake  
 Tooling



**S9927**  
 75mm Die Block Pressbrake  
 Tooling

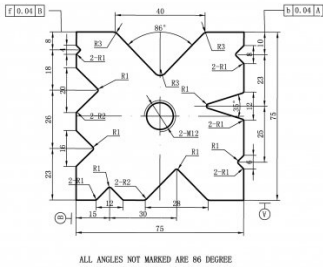

**S991S**  
 86° Top Punch Pressbrake  
 Tooling - Segmented



**S991**  
 86° Top Punch Pressbrake  
 Tooling



**S996**  
 15° Top Punch Pressbrake  
 Tooling



Product Brochure For S902

**S996A**  
 60mm Die Block Pressbrake Tooling

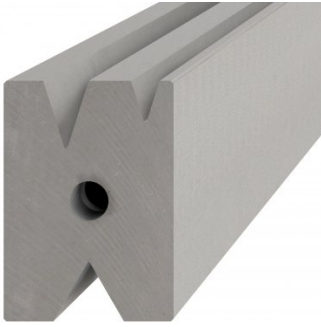

**S996B**  
 60mm Die Rail Pressbrake Tooling



**Q200**  
 Combination Set

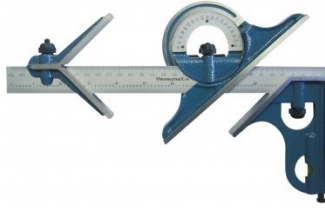

**Q200A**  
 Combination Set



**Q201**  
 Universal Bevel Protractor



**Q2105**  
 Digital Height Gauge



**M970**  
 Digital Angle Rule



**M972**  
 Digital Angle Rule

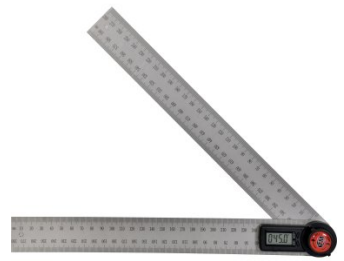

**M974**  
 Digital Angle Rule



**M800**  
 Rubber Mat - Anti-Fatigue



**M805**  
 Rubber Mat - Anti-Fatigue

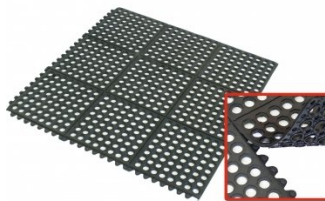

**O000**  
 SpillFix Universal Organic Absorbent



Product Brochure For S902

O043  
 Rust & Corrosion Preventive



O042  
 General Purpose Lubricant & Corrosion Inhibitor



O040  
 Rust & Corrosion Preventive



O044  
 Rust & Corrosion Preventive



O004  
 Superdraulic ISO 46 Hi Temp Hydraulic Oil

