

Product Brochure For S910G

Hydraulic NC Pressbrake - PB-170B

176T x 4000mm - Includes Light Curtain Safety Guarding
 Estun NC-E21 Control 2-Axis with Ballscrew Backgauge & Table
 Crowning



ORDER CODE:	S910G
MODEL:	PB-170B
Control Unit (Type):	Estun NC-E21
Nominal Pressure - Tonnage (Ton):	176
Nominal Pressure - Kilonewtons (kN):	1600
Length of Work Table (mm):	4000
Distance Between Columns (mm):	3200
Throat Depth (mm):	420
Maximum Open Height (mm):	470
Ram Stroke (mm):	200
Machine Axis (No.):	2
Safety Guarding System (Type):	~
Backgauge Travel (mm):	550
Table Bed Crowning System (Type):	Mechanical Crowning System
Motor Power (kW / hp):	11 / 15
Motor Voltage (V):	415
Floor Space Requirements (L x W x H) (mm):	4700 x 2200 x 2900
Nett Weight (kg):	14100



Description

MetalMaster Quality Pressbrakes feature high durability, and provide precision bending capabilities. The Pressbrake main frames are constructed from rolled, stress relieved solid steel to prevent distortion during the bending process and under extreme continuous loads.

MetalMaster Pressbrakes are produced in a high volume production process and therefore are able to be manufactured cost effectively, resulting in affordable price, representing value for money and quicker return on investment.

Featuring an adjustable synchronised torsion bar with positive stop system ensures consistent and accurate bending beam parallelism tolerance to 0.01mm via the digital Control unit.

All electrical components are of European quality supplied by, Telemecanique, Merlin Gerin and ABB.

Features

- Hydraulic / Mechanical ram, synchronised positive stop design, ram stroke controlled by precision mechanical nut depth stops built into each cylinder. Electronically controlled by Estun NC-E21 Programmable digital control assuring accurate repeatability.
- Parallelism is ensured by torsion bar that can be easily adjusted by clutch system.
- Estun NC-E21 programmable digital control stores up to 40 unique programs with 25 automatic progressive bending steps in each individual program, assuring production accuracy & repeatability every time.
- Estun NC-E21 programmable hardened ballscrew backgauge system, simply enter the desired measurement into the controller and press go, the backgauge then will move quickly into the position you have requested. The superior hardened ballscrew system eliminates any backlash that leadscrew type machines produce.
- Manual crowning system allows operator to adjust table bed to correct the deflection that can occur towards the centre of the pressbrake
- Segmented heavy duty 86° offset top punch is segmented for return bend clearance, complete with European style quick release punch holder with an adjustable wedge clamping system for crowning. Intermediate clamp has safety key to stop punch dropping.
- Multi vee ("V") bottom die is made from one 4000mm solid die block design to handle heavy plate, safety edge vee ("V") is incorporated in bottom die block.
- Conveniently mounted control box on pendant for quick swivel and adjustments.
- Mono-block steel frame design, welded then machined to ensure minimal bed deflection under load
- Enclosed rear gate with micro safety switches complete with sliding rear door for easy access.
- European Intermediate clamping system, allowing operator to change position of tooling to suit multiple requirements on complex applications. This feature ensures minimum down time, more productivity and results in reduced cost per finished product.
- Sliding steel fabricated sheet supports enabling a wide range of material sizes to be aligned and supported at the correct required height. This feature is achieved with a "T" slot machined down the total length of the die bed sheet supports are also adjustable vertically to assist in supporting material with return bends already folded.
- Adjustable sliding blocks control the machines beam to provide desirable open height distance to the (slow speed) mute bending point.

Product Brochure For S910G

- Operator adjustable locking knobs for quick adjustment, enables accurate repeatability and increased productivity.
 - Metal safety guarding surrounding the machine with rear sliding door fitted and micro switch ensuring operator safety. Clear access panels placed at each end of machine allows the operator to clearly view tooling and work piece during bending operation. MetalMaster specially design gates to suit Australian safety requirements.
 - Hydraulic MPA pressure gauge mounted on right side of support frame with quick adjusting pressure control knob allowing operator to accurately set the pressure required for different material thickness, incorporating with hydraulic overload protection.
 - Welded steel fabricated synchronised torsion bar horizontally supporting main bending beam to provide consistent parallelism that also can be adjusted for taper correction.
 - The vertical supporting slides are treated to provide greater wear resistance and increased accuracy.
 - Reinforced side frames providing addition support strength to machine throat
 - Includes safety control guarding system with light curtains fitted
 - Mild steel capacity is rated on hot rolled material with 250MPA
- Pre-Commissioning:
 1. Pressbrake is run & tested prior delivery
 2. Hydraulic oil is included with machine

Includes

- Operated by ESTUN NC- E21 control mounted on a swivel pendant for optimal ergonomics
- LED superior bright work lights provides clearer view to workpiece
- Sliding front sheet support arms
- Manual bed crowning system
- Emergency stop buttons conveniently located on control panel and foot control
- Mobile dual operation foot control
- 86 Degree Top Punch with Segments (4x800, 1x365, 1x200, 1x100, 1x50, 1x40, 1x20, 1x15, 1x10)
- Top tooling tool intermediate holder system with wedge type adjustment
- Multi V bottom die block 130 x 130mm with a range of V's between 8mm-100mm
- Premium linear way side mount ballscrew backgauge with 550mm travel
- Metal constructed safety guarding surrounding machine with clear side viewing panels
- Integrated hydraulic system allowing rapid approach switching automatically to slow bend
- Includes safety control guarding system with light curtains fitted

Specific Features



Right View



NC Estun E21 Controller



NC Estun E21



FoldSafe Safety Guard System



FoldSafe Control Box



FoldSafe Control Panel



Safety Guarding



Safety Guarding 2

Product Brochure For S910G



Safety Guarding Left Side



Safety Guarding Close Up Bottom



Safety Guarding Close Up Top



Adjustable Travel Limit Control



Intermediate Clamps



Adjustable Top Tool Taper Wedge System



Tooling Clamps



Tooling Clamps Via Screws



Top and Bottom Tooling



Table Crowning Adjustment via Bolts



Table Crowning Adjustment Bolts

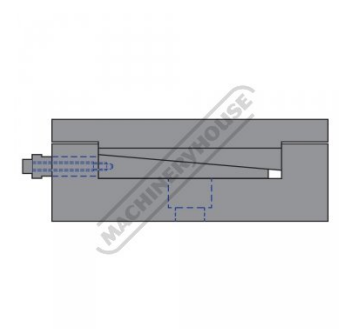

Table Bed Crowning



Enclosed Rear Safety Guarding



Estun NC E21 Control Ballscrew Backgauge



Estun NC E21 Control Ballscrew Backgauge 2



Estun NC E21 Control Ballscrew Backgauge 3

Product Brochure For S910G



Motorised Backgauge

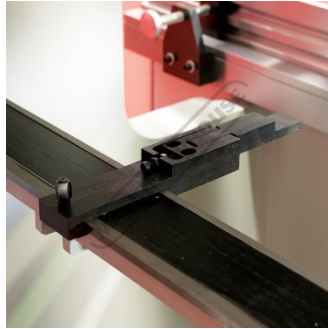

Backgauge Material Stops



Torsion Bar



Adjusting Bottom Stroke Dead Stop Motor



Sheet Supports

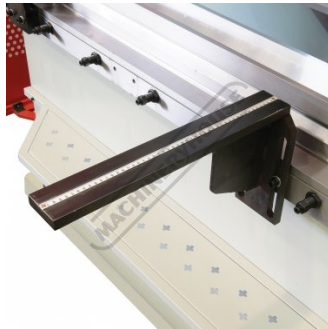

Sheet Supports Close Up



Fine Adjust Backgauge



Adjustable Pressure Gauge

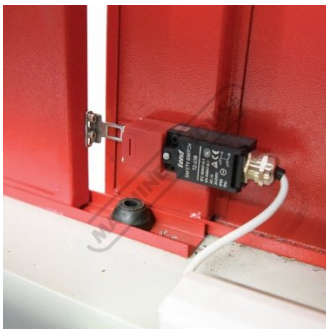

Rear Doors Safety Micro Switch



Mobile Foot Control



Mobile Control Panel

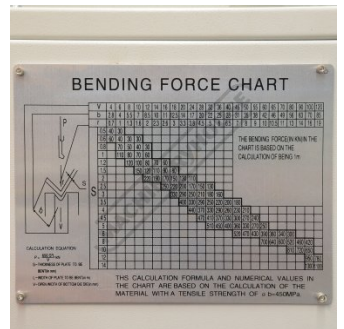

Bending Force Chart

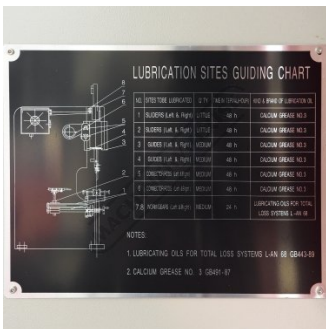

Lubrication Chart

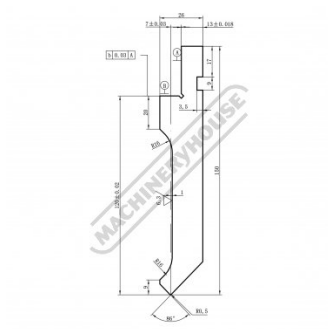

Segmented Top Punch

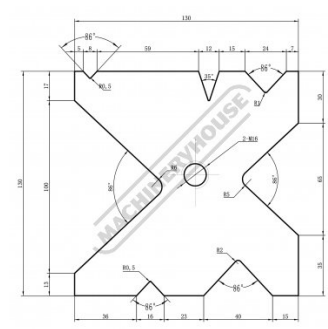

One Piece 4 Sided Die



Shown with Optional Ball Transfer Tables

Product Brochure For S910G

Recommended Accessories

S988
 Quick Action Intermediate
 Clamps



S991
 86° Top Punch Pressbrake
 Tooling



S991S
 86° Top Punch Pressbrake
 Tooling - Segmented



S991F
 86° Top Punch Pressbrake
 Tooling



S994A
 130mm Die Block Pressbrake
 Tooling

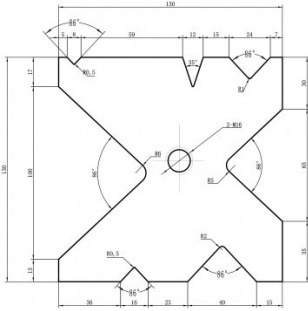

S990
 35° Top Punch Pressbrake
 Tooling



S990S
 35° Top Punch Pressbrake
 Tooling - Segmented



S990F
 35° Top Punch Pressbrake
 Tooling



Product Brochure For S910G

S997
15° Top Punch Pressbrake Tooling



S997A
60mm Die Block Pressbrake Tooling

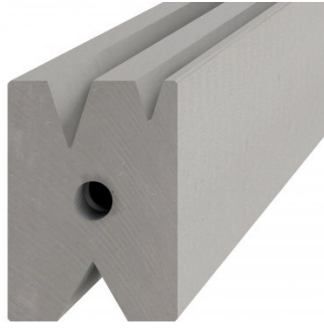

S997B
60mm Die Rail Pressbrake Tooling



Q201
Universal Bevel Protractor



M800
Rubber Mat - Anti-Fatigue



M805
Rubber Mat - Anti-Fatigue

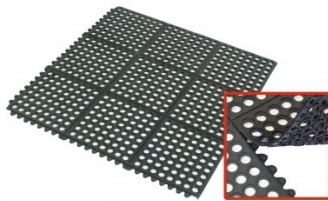

O000
SpillFix Universal Organic Absorbent



O043
Rust & Corrosion Preventive



O042
General Purpose Lubricant & Corrosion Inhibitor



O040
Rust & Corrosion Preventive



O044
Rust & Corrosion Preventive



O004
Superdraulic ISO 46 Hi Temp Hydraulic Oil

