

Product Brochure For T003

Reversible Tapping Chuck - K3-MT3

Include 3MT Fixed Arbor

M6 - M14



ORDER CODE:	T003
MODEL:	K3-MT3
Arbor Mount:	Fixed
Taper (MT):	3
Tapping Range (mm):	6 - 14
Tapping Shank Size (mm):	~
D (mm):	117
D1 (mm):	38
L (mm):	270
L1 (mm):	195
A (mm):	75
B (mm):	13
Nett Weight (kg):	3.26

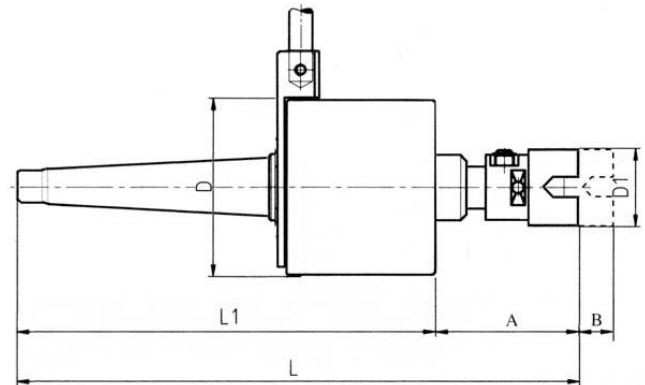

Description

Manufactured in Taiwan

Suits drilling and milling machines

Features

- Clutch device permits smooth drive and reverse
- Pre-set depth control minimises possibility of tap breakage
- Cushioned drive prevents thread distortion and cross-threading when tapping in two operations
- Cushioned reverse provides smooth and vibration-free transition between forward and reverse drive

Product Brochure For T003

Recommended Accessories

T012

Metric Alloy Steel Tap & Die Set
- 32 Piece



T013

Metric HSS Tap & Die Set - 32
Piece



T014

Metric Alloy Steel Tap & Die Set
- 45 Piece



T015

Imperial Alloy Steel Tap & Die
Set - 45 Piece



T016

Metric HSS Tap & Die Set - 45
Piece

