

Product Brochure For V3196

Safeway Stepped Hardened Jaws - 100mm - SJ-100V

#07888076

Ex GST \$250.00
 Inc GST \$275.00



ORDER CODE:	V3196
MODEL:	SJ-100V
Type:	Step Jaws
A (mm):	60
B (mm):	100
C (mm):	22
D (mm):	48
E (mm):	15
F (mm):	M10 x 20 Long
G (mm):	43
H (mm):	5
J (mm):	~
K (mm):	5
L (mm):	10
M (mm):	~
N (mm):	~
Nett Weight (kg):	3



Description

Hardened jaws suitable for clamping work pieces were the finished surface is smooth and needs to be protected.

Features

- Hardened Jaws to HRC55°-58°
- Supplied in pairs

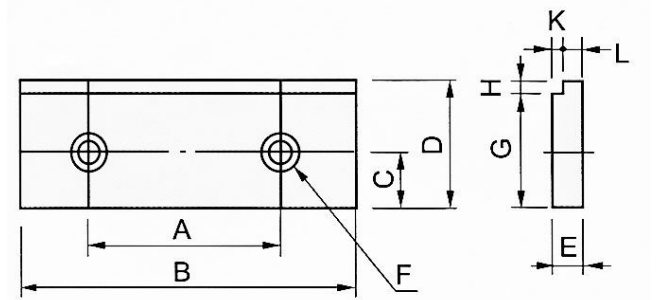

Product Brochure For V3196

Recommended Accessories

V320

Safeway Compact Hydraulic
Vice

