

Product Brochure For W08227

2400 x 1200mm M28 Cast Iron Series Welding Table - WT28-2412CST

Heavy Duty Cast Iron
 Ø28mm Holes



On Sale - New Release

Ex GST	Inc GST
\$3,650.00	\$4,015.00
\$3,540.00	\$3,894.00

ORDER CODE:	W08227
MODEL:	WT28-2412CST
Table Top Finish (Type):	Cast Iron
Table Top Size (mm):	2400 x 1200
Table Height (mm):	800
Table Side Height (mm):	210
Top Plate Thickness (mm):	28
Grid Pattern (mm):	100 x 100
Table Hole Diameter (Ø):	28
Table Slots (mm):	~
Static Load Capacity (kg):	3000
Total W.L.L. (kg):	~
Number of Legs (No.):	6
Nett Weight (kg):	866

METALMASTER



Description

The Metalmaster M28 Cast Iron Series welding tables features heavy-duty cast-iron construction making them the most economical series of our 28mm welding tables. All our M28 Cast Series are manufactured from ISO grade 150 grey cast iron offering high thermal conductivity for uniform heat distribution as well as being naturally resistant to spatter preventing the workpiece from adhering to the table.

The frame is produced using a sand-casting method then CNC machined with the top having a finished nominal thickness of 26-28mm & the 200mm deep sides having a nominal thickness of 20-22mm. The CNC machining process is able to achieve a flatness tolerance of +/- 0.1mm over 1m² to give you a smooth precision welding surface. During this CNC machining process, the Ø28mm holes are precision bored to ensure a hole distance tolerance of +/- 0.05mm & with a 100 x 100mm grid hole pattern it gives you a multitude of fixture holes to suit your application.

Our M28 Cast Series tables have been designed with an internal intersecting rib structure along with 200mm high sides to maintain rigidity & heavy load capacity for all heavy fabrication projects. The table also comes complete with heavy powder coated tube steel legs featuring levelling feet ensuring a stable working surface. Choose from our wide range of optional Pro Series clamping kits & fixturing accessories to add to your table giving you the ultimate welding & fixturing system for your next fabrication project.

Features

- Raw cast iron machined surface finish making it naturally spatter resistant
- Ø28mm Precision bored fixing holes at 100mm centres
- 100 x 100mm hole grid pattern offering a multitude of clamping options
- Precision CNC machined to ensure flatness of +/- 0.1mm over 1m²
- Manufactured from ISO Grade 150 cast iron

Includes

- 6pcs of heavy steel legs c/w with leveling feet

Optional Accessories

- 42pc Welding Clamp Set (W08280)
- It is recommended that a minimum of 2 pairs (4pcs) of the WT28-LFK2 - Table & Accessory Lifting Kit (W08290) when lifting

Product Brochure For W08227

Specific Features

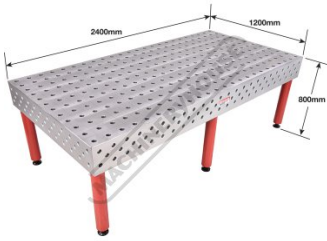

Top View Dimensions



Cast Iron Table Finish

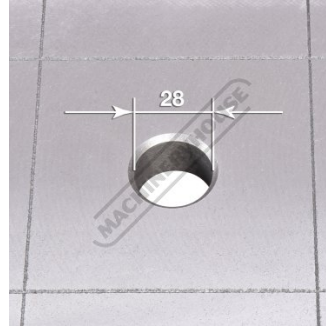

28mm Diameter Holes

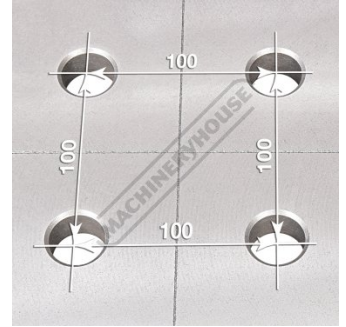

100 x 100mm Hole Centres Diagonal Pattern



M28 Cast Table Series

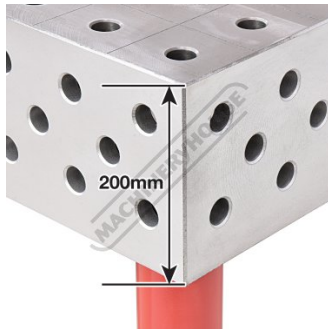

200mm Sides with Extra Centre Holes

Recommended Accessories

W08290

Table & Accessory Lifting Kit



W08280

42pc Welding Table Clamping & Fixturing Kit



W08282

96pc Welding Table Clamping & Fixturing Kit



W08301

180 Degree Welding Table Clamp with T-Bar Handle



Product Brochure For W08227

W08304

90 Degree Welding Table Clamp with T-Bar Handle



W08307

45 Degree Welding Table Clamp with T-Bar Handle



W08375

Magnetic Plug Pin 28 x 25mm



W08373

Double Countersink Lock Pin 28 x 50mm



W08374

Double Countersink Lock Pin 28 x 75mm



W08372

Countersink Ball Lock Pin 28 x 50mm



W08370

Ball Lock Pin 28 x 50mm



W08371

Ball Lock Pin 28 x 75mm



W08360

Cross Type 90 / 120° V-Pad



W08363

120° V-Pad



W08367

Adjustable Height Pad



W08365

75mm Eccentric Pad



Product Brochure For W08227

W08366
 100mm Eccentric Pad



W08357
 Circular Adjustment Shim Kit



W08359
 Rectangular Shim Kit

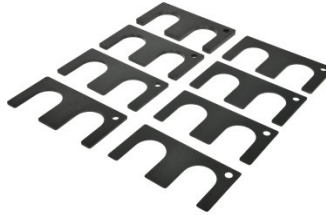

W08340
 Straight Bar Stop



W08341
 Straight Bar Stop



W08342
 Straight Bar Stop



W08343
 Straight Bar Stop



W08320
 Right Angle Bracket / Stop



W08321
 Right Angle Bracket / Stop



W08324
 Right Angle Bracket / Stop



W08325
 Right Angle Bracket / Stop



W08330
 L Bracket



Product Brochure For W08227

W08331
L Bracket



W08335
T Bracket



W08329
Adjustable Angle Bracket



W08326
Angle Bracket Set



W08327
Angle Bracket Set



W08328
Angle Bracket Set



W08350
Riser Block



W08351
Riser Block



W08353
Riser Block



W08354
Riser Block



W1071
Switchable Multi-Angle Welding Magnet



W1072
Switchable Multi-Angle Welding Magnet



Product Brochure For W08227

W1091
 Magnetic Swivel V-Pad Clamps



W10361
 Magnetic TIG Torch Rest



W10362
 Magnetic MIG Torch Rest



W112
 Micro Welding Steel Clamp Set



W113
 Butt Welding Aluminium & Steel
 Clamp Set



W119
 Anti-Spatter Spray

