

Product Brochure For W08254

## 1500 x 1500mm M28 Pro Series Welding Table - WT28-1515N

Plasma Nitriding Coating  
 Ø28mm Holes

**Special Order**

<b>Ex GST</b>	<b>Inc GST</b>
<b>\$6,150.00</b>	<b>\$6,765.00</b>



ORDER CODE:	W08254
MODEL:	WT28-1515N
Table Top Finish (Type):	Plasma Nitriding Coating
Table Top Size (mm):	1500 x 1500
Table Height (mm):	850
Table Side Height (mm):	200
Top Plate Thickness (mm):	25
Grid Pattern (mm):	100 x 100
Table Hole Diameter (Ø):	28
Table Slots (mm):	~
Static Load Capacity (kg):	3000
Total W.L.L. (kg):	~
Number of Legs (No.):	5
Nett Weight (kg):	690



### Description

The Metalmaster M28 Pro Series welding tables features a welded & ribbed construction from heavy S355 plate steel, the frame is then CNC machined with the sides & top having a finished nominal thickness of 25mm. The CNC machining process is able to achieve a high flatness tolerance of +/- 0.1mm over 1m2 to give you a smooth precision welding surface. During this CNC machining process, the Ø28mm holes are precision bored to ensure a hole distance tolerance of +/- 0.05mm & with a diagonal style hole pattern it gives you a multitude of fixture holes to suit your application. Before removing the table from the machining centre, we engrave 100mm grid lines & perimeter ruler to give you millimetre precision helping you minimise mistakes while increasing productivity.

Our Pro Series able have been designed with interlocking solid steel ribs & 200mm high sides to maintain rigidity & heavy load capacity for all heavy fabrication projects. The diagonal style hole spacing is an industry standard 100 x 100mm grid with an additional hole in the centre giving you almost endless possibilities for both welding and clamping applications. The table also comes complete with heavy powder coated tube steel legs complete with heavy duty caster wheels featuring integrated levelling feet ensuring a stable working surface.

All our M28 Pro Series come standard with a plasma nitriding coating which thermochemically case hardens the surface so not only making it harder but also making it spatter, wear & rust resistant.

Choose from our wide range of optional Pro Series clamping kits & fixturing accessories to add to your table giving you the ultimate welding & fixturing system so when you go into battle with your next fabrication project it's a knockout.

### Features

- Plasma nitriding surface finish for increased hardness, rust & spatter resistance
- Ø28mm Precision bored fixing holes at 100mm centres
- Diagonal hole grid pattern offering a multitude of clamping options
- 100mm grid lines & perimeter ruler engraving
- Precision CNC machined to ensure flatness of +/- 0.1mm over 1m2
- Tabletop & sides manufactured from heavy 25mm S355 plate steel

### Includes

- 5pcs of heavy steel legs c/w caster with integrated leveling feet

### Optional Accessories

- 42pc Welding Clamp Set (W08280)
- WT28-LFK2 - Table & Accessory Lifting Kit (W08290)

Product Brochure For W08254

**Specific Features**



Plasma Nitriding Surface Finish

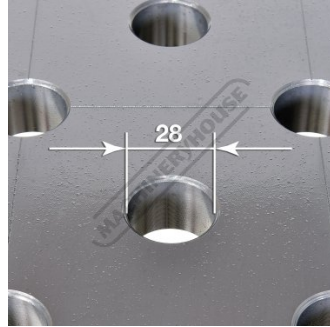

28mm Diameter Holes

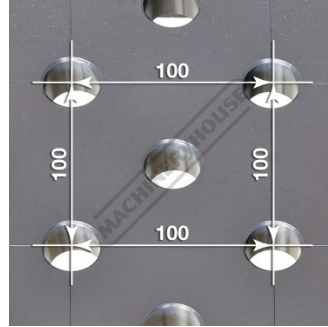

100 x 100mm Hole Centres Diagonal Pattern



Perimeter Ruler Engraving



M28 Pro Table Series



200mm Sides

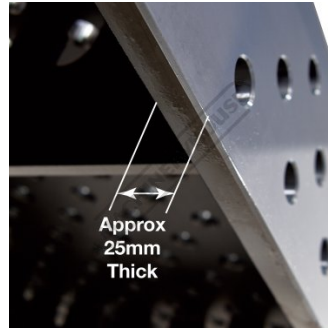

Material Thickness Approx 25mm

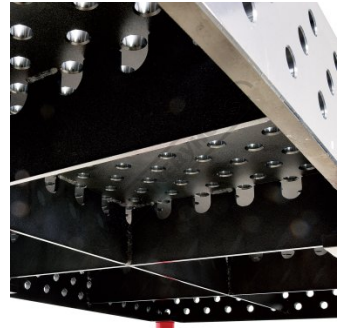

Stenghtened by Welded Webbing



Adjustable levelling castors

Product Brochure For W08254

**Recommended Accessories**

**W08290**  
 Table & Accessory Lifting Kit



**W08280**  
 42pc Welding Table Clamping & Fixturing Kit



**W08282**  
 96pc Welding Table Clamping & Fixturing Kit



**W08301**  
 180 Degree Welding Table Clamp with T-Bar Handle



**W08304**  
 90 Degree Welding Table Clamp with T-Bar Handle



**W08307**  
 45 Degree Welding Table Clamp with T-Bar Handle



**W08375**  
 Magnetic Plug Pin 28 x 25mm



**W08373**  
 Double Countersink Lock Pin 28 x 50mm



Product Brochure For W08254

W08374

Double Countersink Lock Pin 28 x 75mm



W08372

Countersink Ball Lock Pin 28 x 50mm



W08370

Ball Lock Pin 28 x 50mm



W08371

Ball Lock Pin 28 x 75mm



W08360

Cross Type 90 / 120° V-Pad



W08363

120° V-Pad



W08367

Adjustable Height Pad



W08365

75mm Eccentric Pad



W08366

100mm Eccentric Pad



W08357

Circular Adjustment Shim Kit



W08359

Rectangular Shim Kit

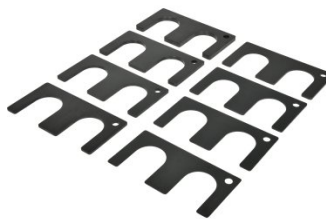

W08340

Straight Bar Stop



Product Brochure For W08254

W08341  
 Straight Bar Stop



W08342  
 Straight Bar Stop



W08343  
 Straight Bar Stop



W08320  
 Right Angle Bracket / Stop



W08321  
 Right Angle Bracket / Stop



W08324  
 Right Angle Bracket / Stop



W08325  
 Right Angle Bracket / Stop



W08330  
 L Bracket



W08331  
 L Bracket



W08335  
 T Bracket



W08329  
 Adjustable Angle Bracket



W08326  
 Angle Bracket Set



Product Brochure For W08254

W08327  
 Angle Bracket Set



W08328  
 Angle Bracket Set



W08350  
 Riser Block



W08351  
 Riser Block



W08353  
 Riser Block



W08354  
 Riser Block



W1071  
 Switchable Multi-Angle Welding Magnet



W1072  
 Switchable Multi-Angle Welding Magnet



W1091  
 Magnetic Swivel V-Pad Clamps



W10361  
 Magnetic TIG Torch Rest



W10362  
 Magnetic MIG Torch Rest



W112  
 Micro Welding Steel Clamp Set



Product Brochure For W08254

W113

Butt Welding Aluminium & Steel  
Clamp Set



W119

Anti-Spatter Spray

