

Product Brochure For W08506

Magnetic Cross Type 90 / 135° V-Pad (4 Piece Pack) - SCVM-90135

Suits welding tables & swivel clamp pads

On Sale - Back In Stock Soon

Ex GST

Inc GST

~~\$25.00~~

~~\$27.50~~

\$20.00

\$22.00



ORDER CODE:	W08506
MODEL:	SCVM-90135
Suits Table Hole Diameter (Ø):	~
Type:	Magnetic Cross V-Pad
Degree Opening:	90 + 135 Degree
Size:	~
Quantity Per Pack (No.):	4
Suits:	Welding Tables & Swivel & Clamp Pads
Nett Weight (kg):	1.0



Description

Magnetic V-Pads are used as a support between the table surface and round workpieces, plus being magnetic, can be used anywhere on the tables or with a fixture accessory. The design of the magnetic base allows for use in any position on the welding table when your workpiece does not line up with one of the table or fixture holes giving you endless flexibility in your clamping tasks. It also can be used on the swivel pad of a welding table clamp when clamping round material.

Features

- Use in any position on a welding table or fixture accessory
- Use on the swivel pad of a welding table clamp
- 90 Degree V to hold up to 20mm round or square on its edge
- 135 Degree V to hold up to 50mm round
- CNC machined surfaces to ensure precision tolerances
- Burnished finish surface treatment to prevent rust

Product Brochure For W08506

Specific Features

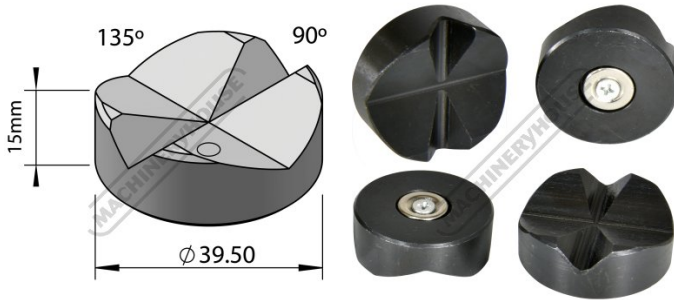

Dimensions

4 Piece Set

Recommended Accessories

W08012

BuildPro V-Block Spacer

