

Product Brochure For W811

Heavy Duty Universal Stand - UTS-3HD

Top Area 400 x 600mm x 500-820mm High
 200kg Max Load Capacity

On Sale

Ex GST

Inc GST

~~\$130.00~~

~~\$143.00~~

\$117.27

\$129.00



ORDER CODE:	W811
MODEL:	UTS-3HD
Maximum Load Capacity (kg):	200
4 x Holes Mounting Dimensions (mm):	~
Top L x D (mm):	600 x 400
Legs L x D (mm):	670 x 470
Height (mm):	500-820 with Adjustable Feet
Centre Frame Height (mm):	~
Nett Weight (kg):	19



Description

The UTS-3HD Heavy-Duty Universal Stand offers an affordable and reliable solution for supporting a wide range of small footprint machines and workshop accessories. Built with a durable 3mm steel plate, it provides a solid and customizable mounting surface to suit various applications.

Capable of holding up to 200kg, the stand features a 600 x 400mm top area and an adjustable height range of 500-820mm. The screw-type adjustable feet allow you to level the stand to your floor for a stable and secure setup.

Note: Some modifications to the top plate may be required to fit your specific machine.

Features

- Top Dimensions: 400mm x 600mm (3mm Top Thickness)
- Heavy Duty Legs: 50 x 50 x 4mm steel angle legs with adjustable feet
- Customizable Mounting: Steel plate top allows for drilling and tapping for secure mounting
- Maximum Load Capacity: 200kg
- Height: Adjustable from 500mm to 820mm with screw-type feet
- This heavy-duty stand offers a strong, customizable foundation for a wide range of machinery.

Product Brochure For W811

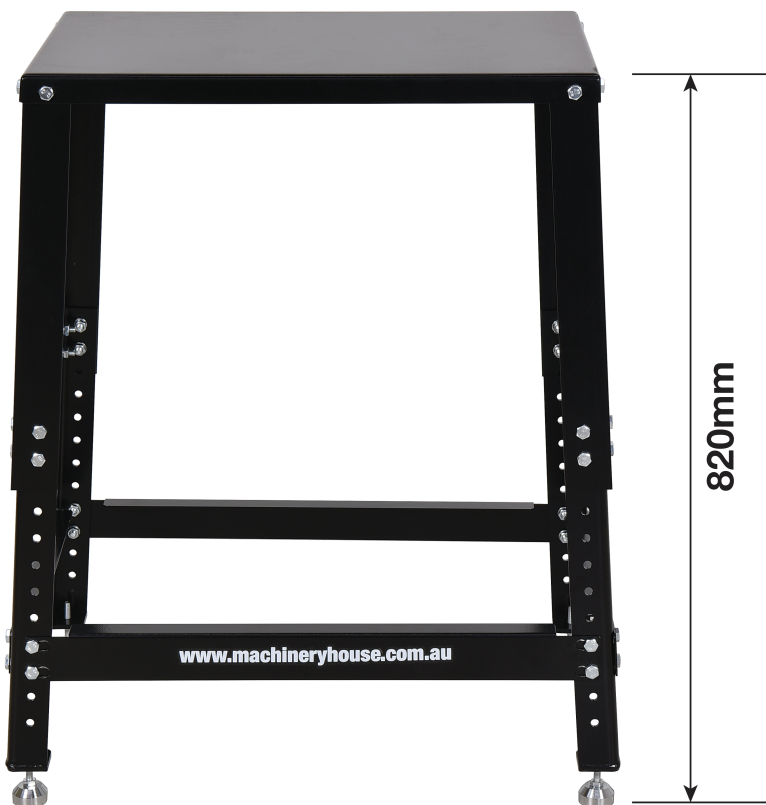
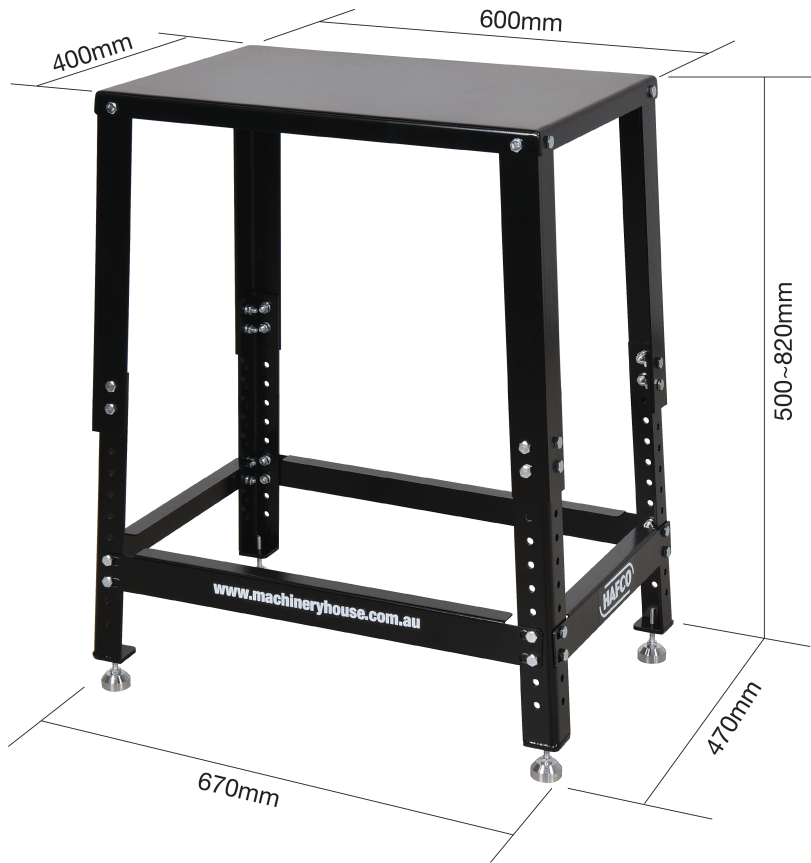

Product Brochure For W811

Specific Features



Front View



Front View Lowest Height



Side View



Low View



Adjustable Height Legs



Adjustable Feet



Dimensions

Recommended Accessories

W350

Variable Speed Scroll Saw

W846

Bench Top Router

W618

Bench Planer Jointer

W843

Vertical Oscillating Bench
 Bobbin Sander



Product Brochure For W811

L105
Belt & Disc Linisher Sander



W859
Wetstone Grinder



W868
Wetstone Grinder



W347
Chisel Morticer

