

Product Brochure For W838

## Industrial 508mm Helical Cutter Head Thicknesser - T-508S

508 x 204mm (W x H) Material Capacity

Includes Helical Cutter Head with Tungsten Carbide Inserts

**On Sale**

Ex GST

Inc GST

~~\$4,990.00~~

~~\$5,489.00~~

**\$4,690.00**

**\$5,159.00**



ORDER CODE:	W838
MODEL:	T-508S
Material Width Capacity (mm):	508
Material Height Capacity (mm):	204
Minimum Material Length (mm):	190
Maximum Depth of Cut (mm):	6mm @ 508mm wide
Cutter Type:	Carbide Inserts - Helical
Quantity of Cutters (No. x Type):	130 x Inserts
Cutter Block Diameter (mm):	~
Cutter Block Speed (rpm):	~
Quantity of Spirals (No.):	6
Length of Table (mm):	~
Length of Table with Extensions/Rollers (mm):	~
Feed Speed (m/min):	4.2 / 5.1
Dust Outlet Diameter (mm):	100
Motor Power (kW / hp):	3.75 / 5
Voltage / Amperage (V / amp):	415
Floor Space (W x D x H) (mm):	~
Floor Space With Option Stand (W x D x H) (mm):	~
Nett Weight (kg):	342



### Description

The HAFCO Woodmaster T-508S thicknesser is an industrial quality 508mm (20") machine that comes standard with a helical cutter head. The advantage of a helical cutter head is its spiral shearing action with the workpiece, this translates into a smoother surface finish with less chipping and tear out of the workpiece, as well as a quieter operation compared to the very loud chopping effect produced by a traditional HSS blade cutter-head.

The helical cutter head includes 130 tungsten carbide inserts, not only giving you a superior finish but when maintenance is required just simply index or replace blunt or damaged inserts meaning there is no fiddly height setting to be carried out. The cutter head is supported by 4 x solid pillars at each corner giving you a ridged & accurate machine. The T-508S has a two-speed gearbox with a feed rate of 4.2 or 5.1mpm and the steel drive roller have ribbing to ensure positive grip on the timber through the machine. The digital depth indicator will help ensure you are removing the precise amount of material each cut. Power is provided by a heavy duty 3750W / 5HP 415V induction motor, housed within the base and transmitting power to the cutter block via a twin pulley vee belt drive system.

Overall, the HAFCO Woodmaster T-508S Thicknesser offers accuracy & precision along with high quality finish to your next woodworking project.

### Features

- 508mm wide x 204mm high timber capacity
- Dynamically balanced solid steel 6 helical cutter head with 130 pre-loaded tungsten carbide inserts
- Tungsten Carbide inserts incorporate 4 cutting edges per insert
- High output 5HP 415V induction motor located in the enclosed stand
- Solid cast iron construction
- Cast iron in-feed & out-feed tables
- 2 speed feeding gearbox with feed rates of 4.2 or 5.1mpm
- Digital cutting height gauge
- Base mounted wheel kit supplied as standard
- Ø100mm dust chute

### Includes

- Includes 130 Carbide Inserts - Dimension Shown Below.

Product Brochure For W838

Specific Features



Right View



Top View



Left View



Rear View



Heavy Duty 4 Post Design



Control Panel



Digital Height Gauge



Table Lock Handle

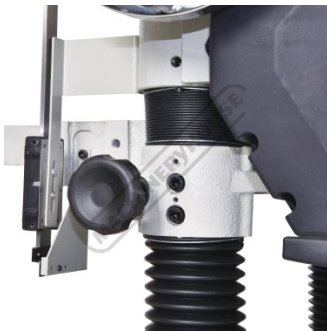

Table Lock and Screws for Fine Adjustment



Height Adjustment Hand Wheel



2 Speed Feed Gearbox



Anti Kick Back Fingers



Six Spiral Cutter Head Top View



Six Spiral Cutter Head Top View Close Up



Six Spiral Cutter Head Changing Insert



Moveable on Wheels

Product Brochure For W838



Lever Action Front Wheel



Rear Wheels



Adjustable Stop



Cast Iron Infeed and Outfeed Tables

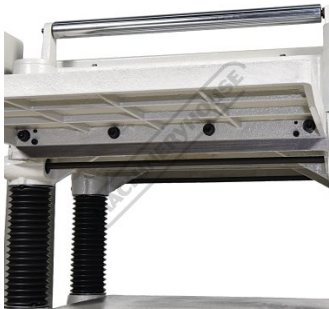

Cast Iron Table Are Adjustable



Top Rollers for Returning Material



100mm Dust Outlet

**Recommended Accessories**

**W840**

Tungsten Carbide Inserts for Helical Cutter Heads on Thicknesser



**W394**

Dust Collector



**W931**

Mobile Base - Heavy Duty



**W329**

Dust Collector



Product Brochure For W838

**W344**  
 Wood Dust Accessory Kit



**W334**  
 Dust Hose Reducer



**W333**  
 Dust Hose Reducer



**W335**  
 Blast Gate



**W336**  
 Dust Hose Elbow - 90 Degree



**W337**  
 Dust Hose Y Adaptor



**W338**  
 Dust Hose Universal Dust Hood



**W339**  
 Dust Hose Floor Sweeper Attachment



**W340**  
 Dust Hose Clamp



**W341**  
 Dust Hose Clamp



**W343**  
 Roller Stand



**W343A**  
 Roller Stand



Product Brochure For W838

---

W3434  
Roller Stand

